

## Countersunk Head Nutsert

**Body Type:** Round Open

**Outside Body:** Splined | Knurled

**Thread Type:** Metric - Coarse

**Body Material:** Stainless Steel

**Class Grade:** A4-70 G316

**Finish:** Stainless Steel A4-70 G316

**Corrosion Protection Level:** Ultimate

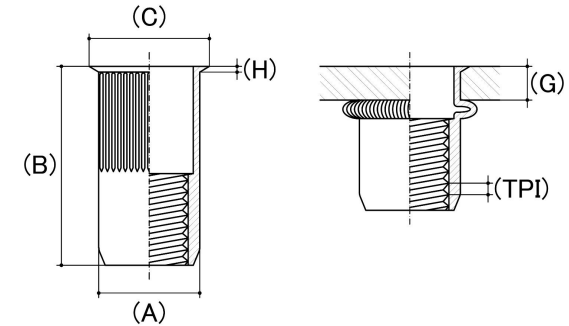

*CAD drawings shown for graphic representation only.\**

Size	Thread Pitch (mm)	Thread Type	Material Grip Range (G) (mm)		Overall Nut Height (B) (mm)	Head Diameter (C) (mm)	Nut Width (A) (mm)	Flange Thickness (H) (mm)	Recommended Hole Size (mm)	Pull Out (KN)	Push Out (KN)	Torque To Turn (NM)	sku (qfind)
			Min	Max	Nom	Nom	Nom	Nom	Nom	Nom	Nom	Nom	
M3	0.50	Coarse	0.50	2.00	9.00	6.00	4.95	0.50	5.00	-	-	-	43CS3SPM
M4	0.70	Coarse	0.50	2.50	11.00	7.00	5.95	0.50	6.00	3	1	2	43CS4SPM
M5	0.80	Coarse	0.50	3.00	12.00	8.00	6.95	0.50	7.00	7	1	2	43CS5SPM
M6	1.00	Coarse	0.50	3.00	14.00	10.00	8.95	0.50	9.00	15	2	5	43CS6SPM
M8	1.25	Coarse	0.50	3.00	16.00	12.00	10.95	0.50	11.00	18	3	9	43CS8SPM
M10	1.50	Coarse	1.00	3.50	19.00	14.20	12.95	0.80	13.00	-	-	-	43CS10SPM

**Disclaimer:**

Dimensional data and technical information was obtained from publicly available sources and not acquired through standard agencies. It has been completed and compiled for reference purposes only; where discrepancies are found they are subject to change without notice. Bolt & Nut Australia makes no warranties or representations regarding the accuracy and validity of the compiled information and data. Contact the relevant standard authorities for accurate and detailed information.

\* CAD drawings may not reflect diameter, thread length or overall length.

© Bolt & Nut Australia Pty Ltd. All rights reserved.

Version: 18 Mar 2024